



# Version 1

## User Manual

This product is protected by granted and pending patents in multiple countries. As the sole inventor and supplier of the UpGate®, we hold exclusive rights to its technology. Our commitment to innovation is reflected in the extensive intellectual property protection we have secured to safeguard our technology. For more details, please refer to section 10 of this manual.

**SAFETY WARNING!** Read this manual entirely before installation and use.

Made in Australia

# Contents

1. Introduction .....	3
2. Safety Instructions.....	4
3. Operation.....	6
3.1 Basic Operation Concept .....	6
3.2 Adjusting the Closed Height of the Bungy Cords.....	6
3.3 Handheld Remotes .....	7
3.4 Release Button.....	8
3.5 Manual Operation Button.....	8
3.6 Fault Menu.....	8
3.7 Menu Navigation .....	9
3.8 Adding or Removing Bungy Cords .....	9
3. Installation .....	12
Step 1 – Select or install an appropriate gateway.....	12
Step 2 – Unpackage Next to Proposed Gateway.....	13
Step 3 – Install Joiner Plate Lower Two Bolts.....	14
Step 4 – Install Solar Panel Arm Assembly .....	15
Step 5 – Partially Install Upper Track.....	16
Step 6 – Install Required Shuttles .....	17
Step 7 – Fully Install Upper Track and Top Cap .....	18
Step 8 – Pre-Drill Post Using Template.....	19
Step 9 – Fix to Post with Bottom Screw .....	20
Step 10 – Rotate the Whole Assembly into Place and Fix.....	21
Step 11 – Install Solar Panel Bird Spikes.....	22
Step 12 – Install Earth Stake.....	23
Step 13 – Connect Battery and Power Up Circuit Board .....	24
Step 14 – Install Bungy Cords.....	25
Step 15 – Adjust Bungy Closed Heights .....	25
Step 16 – Adjust the Program Settings.....	26
Step 17 - Connect Up Electric Fence .....	27
Step 18 – Programming Remotes.....	27
Step 19 – Test .....	27
4. Maintenance .....	28
5.1 Six Monthly Maintenance.....	28

5.2	Two Yearly Maintenance.....	28
5.3	Placing into Maintenance Position .....	29
5.4	Reinstate from Maintenance Position .....	34
5.5	Replacing a Broken or Damaged Belt .....	38
5.6	Tightening a Loose Belt.....	40
5.7	Replacing Shuttles.....	40
5.8	Replacing an Insulator .....	41
5.9	Replacing Bungy Cords .....	41
5.10	Replacing Battery .....	41
5.11	Updating Firmware .....	43
5	Troubleshooting .....	44
6	Warranty .....	47
7	Technical Specifications .....	49
8	Spare Parts .....	49
9	Intellectual Property.....	50

## 1. Introduction

Welcome to the UpGate® User Manual!

Congratulations on your purchase of the UpGate® by ControlAg. Get ready to streamline your farm operations like never before.

The UpGate® is a groundbreaking gate opener specifically designed for cattle farms utilising electric fence systems. With its innovative design and versatile functionality, the UpGate® will revolutionise the way you manage your livestock.

The UpGate® can accommodate from 1 to 4 bungy cords. The less bungy cords you install the faster the UpGate® will run. Whether you prefer swift operation or maximum security, the choice is yours.

Before diving into installation and operation, it is crucial to thoroughly review all instructions provided in this manual, especially the [Chapter 2. SAFETY INSTRUCTIONS](#). Safety and efficiency are our top priorities, and understanding proper usage is essential for optimal performance.

Controlled effortlessly via a handheld wireless remote control or manual button located on the underside of the housing, the UpGate® ensures convenience and ease of use.

Additionally, we have included detailed six-monthly and two-yearly maintenance schedules to keep your UpGate® operating smoothly for years to come.

Thank you for choosing the UpGate® by ControlAg.



## 2. Safety Instructions

1. **READ ALL INSTRUCTIONS CAREFULLY AND COMPLETELY BEFORE** attempting to install and use this automatic gate opener.
2. This gate opener moves quickly and with a high level of force. Stay clear of the unit while it is operating and exercise caution at all times.
3. Do not connect anything other than an approved animal electric fence system that complies with AS/NZS 3014 standards to the UpGate® contact plate terminal.
4. Ensure there is an existing electric fence system isolator in good working order within two metres of the UpGate® for isolation of the UpGate® bungy cords in emergency situations.
5. During the first time taking any vehicle through the open gateway, get someone to watch from a safe distance and give advice as to whether your vehicle will clear underneath the open bungy cords safely. We recommend at least a 300mm clearance to be safe.
6. If a vehicle will not fit under the gate, operate the gate into the closed position, and un-hook and open the bungy cords as you would normally if the UpGate® were not installed.
7. Never assume that because your vehicle has cleared underneath the bungy cords safely before, that it will do so again. While approaching the gateway, visually inspect that the bungy cords are in the highest possible position, and the bungy cords are not loose or sagging more than usual. This is especially important if you are in a vehicle that usually only clears underneath the bungy cords by a small margin in normal circumstances.
8. When passing through an UpGate® with a front end loader, be very cautious, especially if you are turning a corner so as not to contact the UpGate® posts with the front end loader. This will cause a lot of damage if you do so.
9. When passing through an open gateway, drive very slowly, less than 10km/h, giving yourself time to react in case of inadvertent operation, or misjudgement of vehicle height.
10. When opening the gate, watch carefully to make sure the bungy cords make it all the way to the top before they stop to ensure maximum clearance is provided.
11. Ensure a high visibility flag is attached to the highest positioned bungy cord at all times.
12. Keep remotes away from children and do not put remotes in a place that could cause accidental operation of a button and therefore inadvertent gate operation.
13. Before performing any maintenance refer to the maintenance instructions for safe guidance on how to do so.
14. Do not install, mount or change any parts to the UpGate® that are not supplied by ControlAg.
15. Do not install or operate an UpGate® within 15 metres of any power lines, vertically or horizontally from the closest point of the UpGate®.
16. As the owner of the UpGate® you shall ensure any potential users of the gate have read and have access to these Safety Instructions for the UpGate®.
17. As the owner of the UpGate® you shall undertake your own risk assessment for safe use of the UpGate® in the location you install it, and employ any extra safety measures you identify.
18. Do not install the UpGate across a public road.
19. If you install an UpGate® near public footpaths, roadways, boundary fences, or likely to be used by users unaware of the function and risks of the gate, you must label the Electric bungy cords with a "WARNING-ELECTRIC FENCE" sign complying with AS/NZS 3014 standards. You must also provide effective signage warning any potential unaware users that the gate is automatic and may operate at any time without warning.
20. During nearby electrical storms (lightning) do not be near an UpGate® unless you are in an enclosed vehicle with windows and doors closed.

21. When operating an UpGate® around animals, especially if the animals have not experienced regular operation near an UpGate® before, it is strongly advised to be on, or in a vehicle. Animals can sometimes be “spooked” by the sudden movement and sound of the UpGate® operating and they may run in any direction, possibly causing injury or death to bystanders.
22. If high wind conditions are expected (greater than 80 km/h), the UpGate must be placed in the closed position.

## 3. Operation

### 3.1 Basic Operation Concept

#### **Operation**

The UpGate is an automated gateway designed for cattle farms. It is operated using a handheld wireless remote control, with a button on the UpGate control box provided as a backup.

Each UpGate is assigned to a specific button on the remote control. When programmed correctly, the label on the remote button will correspond with the label on the UpGate.

A single press of the assigned button will:

- Open the UpGate if it is closed, or
- Close the UpGate if it is open

Pressing the button again during operation will stop the gate and reverse its direction.

The UpGate does not close automatically. To close the gate, press the same button again on the remote control. Always visually confirm that the gate has fully closed before leaving the area.

Each UpGate operates independently. Where two UpGates are installed at a single gateway, each unit must be controlled separately using its assigned button.

To prevent signal interference, each UpGate within a 200 metre radius must be assigned a unique label and remote button. The same label may be reused for UpGates located more than 200 metres apart.

#### **Wind Conditions**

**Important:** If high wind conditions are expected (greater than 80 km/h), the UpGate must be placed in the closed position.

Failure to secure the UpGate during high wind conditions may result in damage. Damage caused by high winds or severe weather is not covered under warranty.

### 3.2 Adjusting the Closed Height of the Bungy Cords

**Step 1** - Isolate the electric fence system.

**Step 2** - Press the release button and move the lowest shuttle by hand above the position you need it to stop. The release has a one minute timer, press again at any time if you run out of time.

**Step 3** - Move the 40mm stopper pin bolt on the contact plate to the hole you need.

**Step 4** – Press the release button again if it has timed out and move the shuttle down onto the stopper bolt.

**Step 5** - Shuttles 2, 3 and 4 can be moved by hand without pressing the release button. Adjust the stopper bolt heights as necessary (corresponding bolt lengths detailed below). Leave the un-used stopper bolts stored in a spare hole on the contact plate.

Shuttle 2 (2<sup>nd</sup> lowest shuttle) will stop at the position you install the 17mm (entire length) shoulder bolt.

Shuttle 3 (3<sup>rd</sup> lowest shuttle) will stop at the position you install the 14mm (entire length) shoulder bolt.

Shuttle 4 (highest shuttle) will stop at the position you install the 13mm (entire length) cap head bolt.

**Step 6** - If you did change the Stop Position you will need to adjust the program settings. Navigate down to Settings → Stop Position → Set Stop Position. Enter the Stop Position setting to correspond with the position of the stopper of the lowest bungy as explained below, then press enter. The stopper holes on the contact plate are numbered as below with 1 being the lowest and 7 being the highest.

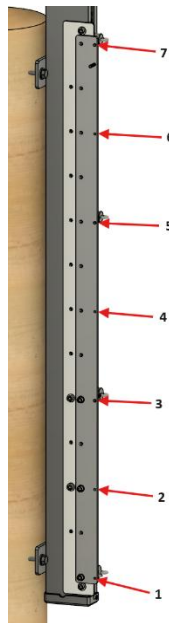

**Step 7** - After you have set this setting, wait for 5 seconds until the “Close gate with release button” message appears. You have already closed it in the earlier step so you may now operate the gate.

**Step 8** - De-isolate the electric fence system.

### 3.3 Handheld Remotes

Adding a new remote button to an UpGate.

- Navigate from Main Menu → Remotes → Add New Remote. Press the button number on your remote that corresponds to the number on the UpGate<sup>®</sup>. For example, if the UpGate<sup>®</sup> is labelled “3”, press button 3 on your remote. A message will display on the screen “Button added”.

Deleting a remote button

- Navigate from Main Menu → Remotes → Delete Remote. Press the button number on your remote that you would like to delete from that UpGate<sup>®</sup>. A message will display on the screen “Button deleted”.

## Deleting all saved remote buttons

Only do this if you want to completely clear that UpGate®'s memory of all its programmed remotes. Once you do this you will have to reprogram all remotes.

- Navigate from Main Menu → Remotes → Clear Remotes, hold Enter for three seconds. Hold down the enter button for three seconds until a message displays “All remotes cleared”.

## 3.4 Release Button

The release button located on the front of the control board releases the brake which holds the lowest bungy cord in place when not operating. This allows you to manually move the bungy cords by hand. This is useful when completing maintenance or adjustments, or after a failed operation it allows you to pull the bungy cords down by hand. You can press the button again to stop the release, otherwise there is a one-minute timeout. The screen displays whether this function is ON or OFF.

## 3.5 Manual Operation Button

On the underside of the enclosure there is a manual operation button (pictured below). Pressing this button acts the exact same way as if you pressed a button on your remote control. This button is very useful if you have forgotten or lost your remote control.



## 3.6 Fault Menu

The fault menu, located within the Main Menu, displays the number and readout of any faults. Scrolling to the Faults heading in the Main Menu you can quickly see if there are any faults present as it will display “No Faults” or the number of faults. If there are faults present, press the enter button to enter into the fault log where you can scroll through the active faults. Refer to the troubleshooting guide in this manual to help you rectify the fault.

### 3.7 Menu Navigation

Navigating the LCD interface is explained in the below tree diagram. Press the Enter button to enter into a menu. Hold the Enter button for atleast two seconds to exit a menu.

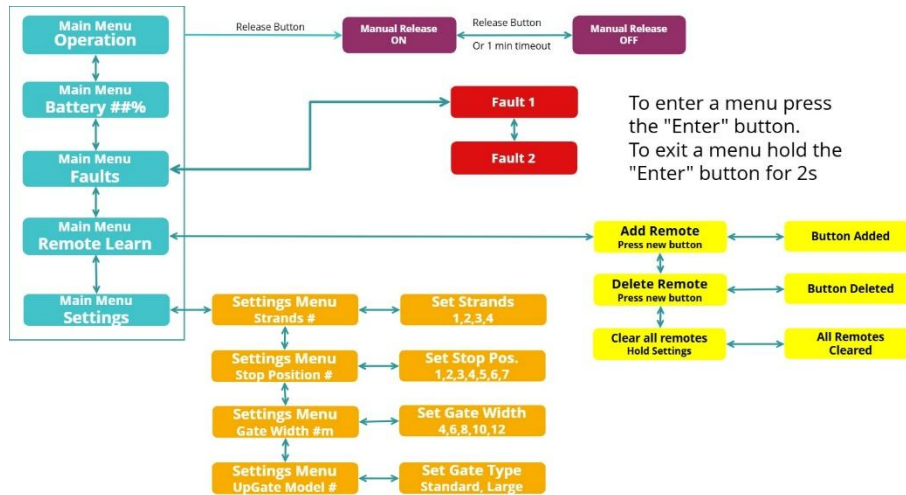

### 3.8 Adding or Removing Bungy Cords

The UpGate® can accommodate from one to four bungy cords depending on your preference. The less bungy cords installed the faster the UpGate® will operate. Each bungy cord requires its own shuttle installed in the track.

**Step 1** - Place the gate into the [5.3 Maintenance position](#), then return back here to continue on.

**Step 2** - Add or remove shuttles as desired. Shuttles are labelled and ordered from 1 to 4 as pictured below, with the lowest shuttle being labelled number 1, and the highest labelled number 4. The maximum amount of shuttles is four and each shuttle must be unique. Do not install two identical shuttles (both with the same number). Also, do not install shuttles if you do not intend on using them.

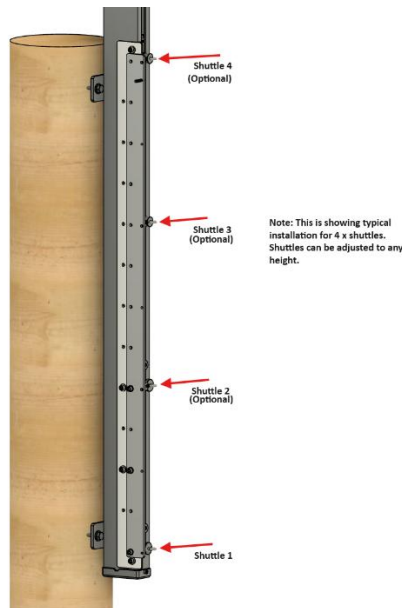

**Step 3** - Double check all the shuttles are in the correct order and are not upside down.

**Step 4** - Follow the instructions [5.4 Reinstall from maintenance position](#). Then return back here to continue on.

**Step 5** - Isolate the electric fence system

**Step 6** - Install a bungy cord kit. One end will have a blue handle that electrically connects the bungy cord to the handle hook. If you are using an UpGate on just one side, the other end of the bungy cord will connect to a post with an insulator. If you are using an UpGate on both ends, the other end of the bungy will connect to the other UpGate with a red insulated handle (this will be the UpGate not connected to your electric fence system). Leave some extra length on the bungy cord as loosening the bungy may be required in a later step.

**Step 7** - Press the release button and move the lowest shuttle by hand above the position you need it to stop. The release has a one minute timer, press again at any time if you run out of time.

**Step 8** - Move the 40mm stopper pin bolt on the contact plate to the hole you need.

**Step 9** – Press the release button again if it has timed out and move the shuttle down onto the stopper bolt.

**Step 10** - Shuttles 2, 3 and 4 can be moved by hand without pressing the release button. Adjust the stopper bolt heights as necessary (corresponding bolt lengths detailed below). Leave the un-used stopper bolts stored in a spare hole on the contact plate.

Shuttle 2 (2<sup>nd</sup> lowest shuttle) will stop at the position you install the 17mm (entire length) shoulder bolt.

Shuttle 3 (3<sup>rd</sup> lowest shuttle) will stop at the position you install the 14mm (entire length) shoulder bolt.

Shuttle 4 (highest shuttle) will stop at the position you install the 13mm (entire length) cap head bolt.

**Step 11** – Change the program settings to suit your adjustments.

Navigate down to Settings → Strands → Set Strands. Change the number to the number of bungy cords installed on the gateway, then press Enter.

Navigate down to Settings → Stop Position → Set Stop Position. Enter the Stop Position setting to correspond with the position of the stopper of the lowest bungy as explained below, then press enter. The stopper holes on the contact plate are numbered as below with 1 being the lowest and 7 being the highest.

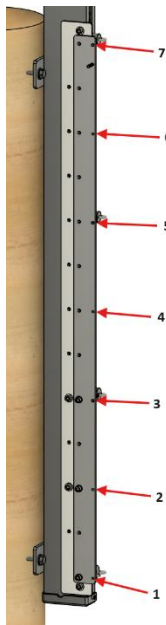

**Step 12** - After you have set this setting, wait for five seconds until the “Close gate with release button” message appears. You have already closed it in the earlier step so you may now operate the gate.

**Step 13** - De-isolate the electric fence system.

### 3. Installation

The following installation process usually takes around 45-60 minutes per UpGate.

#### Step 1 – Select or install an appropriate gateway

Fence posts must be at least 150mm (6 inches) in diameter and protruding at least 1000mm out of ground, and buried at least 1200mm underground.

The fence post must be in good condition and within three degrees of level.

The fence posts must be a minimum of six metres apart.

Be at least fifteen metres clear of any power lines, vertically or horizontally.

Be clear of shade for at least 4-6 hours of each day. This is especially important if the gate will experience a high volume of traffic. The more sun, the more operations it will perform.

If you install an UpGate® near public footpaths, roadways, boundary fences, or likely to be used by users unaware of the function and risks of the gate. You must label the Electric bungy cords with a “WARNING-ELECTRIC FENCE” sign complying with AS/NZS 3014 standards. You must also provide effective signage warning any potential unaware users that the gate is automatic and may operate at any time without warning.

## Step 2 – Unpackage Next to Proposed Gateway

Isolate the electric fence supply for any nearby fencing as you do not want to accidentally get a shock during installation.

Install two assembly stands into each of the lower tracks by twisting them 90 degrees.

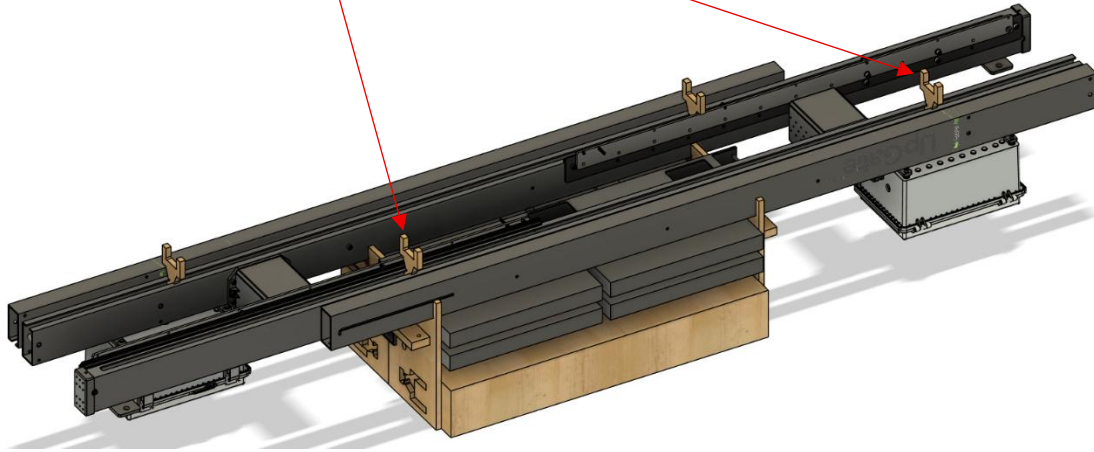

**WITHOUT** twisting or rotating the upper track, place it into the assembly stands.

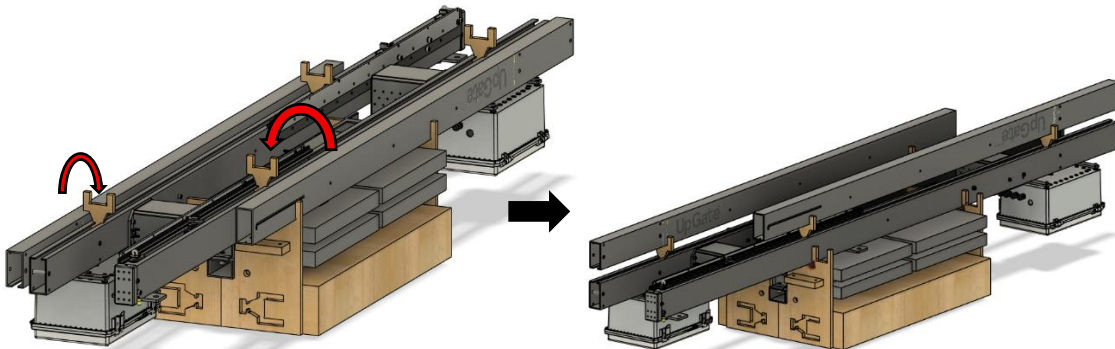

Separate the UpGates from the pallet and place the control board enclosure on something soft like grass or cardboard to protect the face of it.

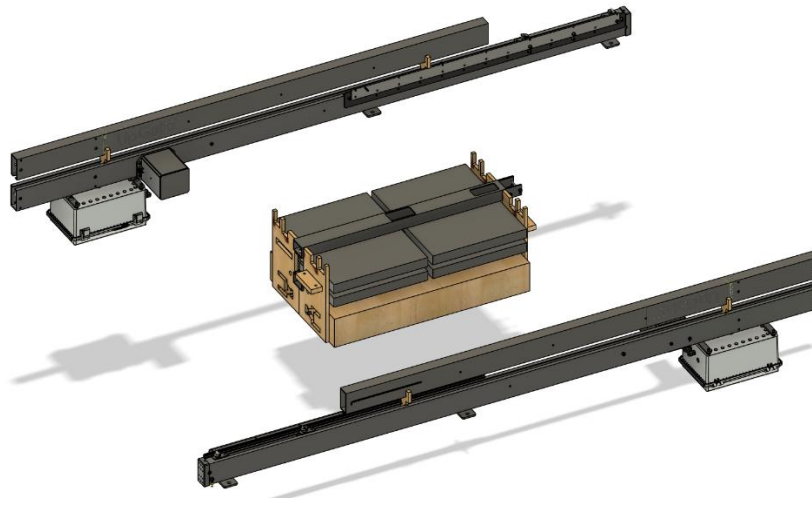

### Step 3 – Install Joiner Plate Lower Two Bolts

Install the two joiner plates with two of the joiner plate bolts (M6x60mm bolts) as pictured below, taking care that the belts pass **ABOVE** the lowest bolt.

**IMPORTANT:** Do not tighten up the nuts, leave them loose, they will be tightened in a later step.

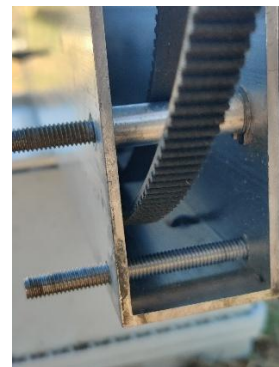
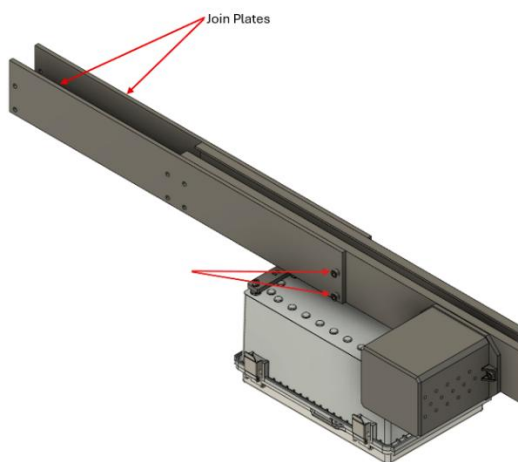

Image showing example of a belt passing ABOVE the lowest bolt.

#### Step 4 – Install Solar Panel Arm Assembly

The solar panel can be installed in one of two different angled positions. Plan to attach the solar panel so it faces in a northerly direction if in the southern hemisphere or southerly direction if in the northern hemisphere.

Install the solar panel arm using the two solar panel mounting bolts (M6x70mm bolts) as pictured below onto the lower half of the track as pictured with the angle you decided. You may need two people for this job as it can be tricky to install these bolts. Persist with gently wriggling the aluminium components until the bolts loosely pass through. Take care that the bolts pass **ABOVE** the lowest bolt as shown in Step 3.

**IMPORTANT** – Do not tighten up the nuts, leave them loose, they will be tightened in a later step.

Connect the electrical plugs from the solar panel to the electrical plugs on the track.

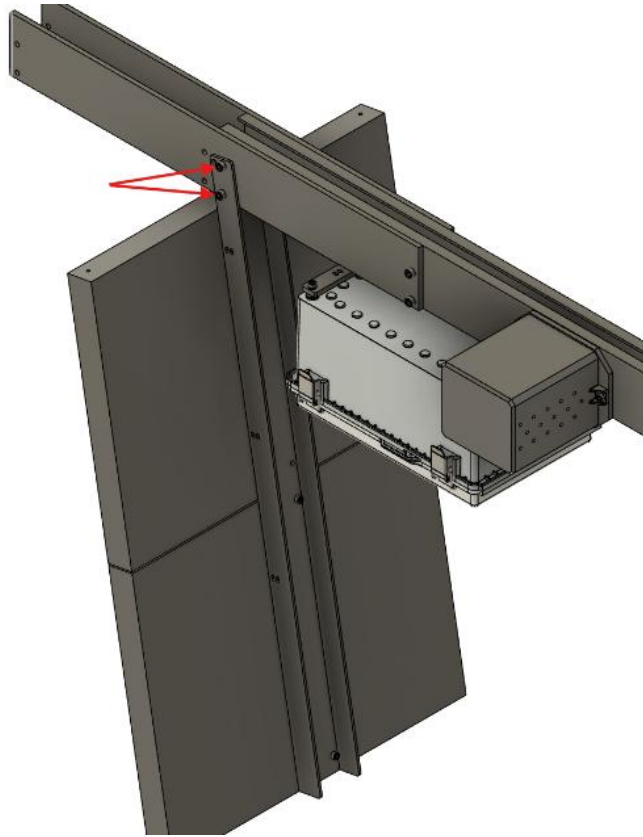

## Step 5 – Partially Install Upper Track

The system should look like the below standing on the solar panel.



Without twisting the upper track carefully rotate the upper track into the pictured position. This is the maintenance position.



Install the one bolt (pictured below) but do not tighten the nut, and make sure the belts pass **ABOVE** the bolt as pictured in step 3.



## Step 6 – Install Required Shuttles

Usually you can skip this step as the shuttles are pre-installed at purchase, however if you have changed your mind on how many bungy cords you need since purchase, then proceed with this step.

The shuttles are labelled from 1 to 4. Shuttle number 1 is pre-installed and connected to the belt. If you require more than one bungy, then install more shuttles. one bungy cord= one shuttle, two bungy cords= two shuttles and so on. The shuttles must go in order, with the lowest shuttle being labelled 1 to the highest shuttle being labelled 4. For example, the shuttle labelled 1 is already installed and will be the lowest shuttle. If you want two bungy cords, place a shuttle labelled 2 above shuttle 1. Shuttles 2, 3 and 4 do not connect to the belt. Do not worry about the height of where the bungy cords will be in the closed position for now, this will be set at a later step.

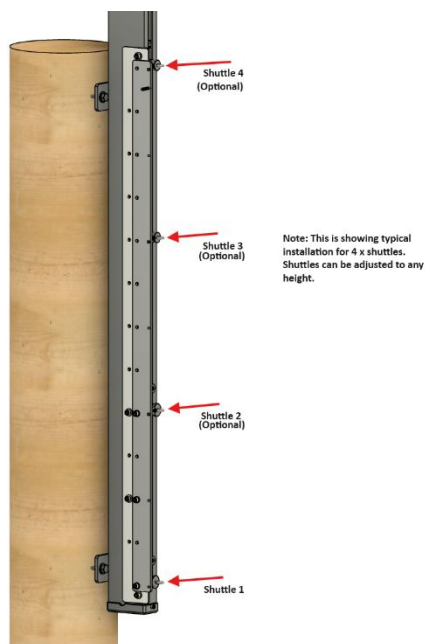

## Step 7 – Fully Install Upper Track and Top Cap

Rotate the upper track into position being **careful not to jam the belt** in between the ends of the two tracks.

Place in the remaining joiner plate bolts as pictured below, taking care that the belts pass **ABOVE** the lower bolt as pictured in step 3.

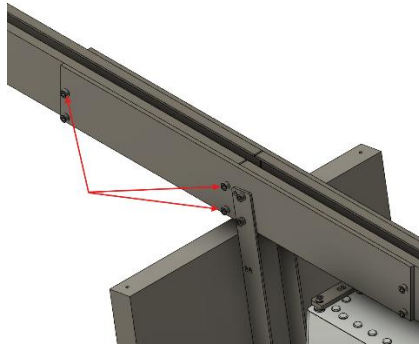

Tighten all eight join plate nuts only to the point the **washer stops feeling loose**, **DO NOT OVERTIGHTEN** the nuts. Any tighter than this and it will start to deform the track and can cause jamming of the shuttles during operation.

Loosen the top tensioner pulley wing nut as pictured below just enough so it will slide in the slot. Locate the belt onto the pulley and pull the bolt so it locks into the highest point in the slot and tightens the belt. Tighten up the wing nut by hand.



Looking down the centre of the tube you should not see any twists in the belt.

Install the top cap using the supplied bolt as pictured below.



Remove the timber assembly clamps by twisting 90 degrees.

#### Step 8 – Pre-Drill Post Using Template

With the supplied tek screws, screw the timber template to the post using into the desired position(recommend the top of the template to be level with the top of the post). Take some time getting the angle right so it faces as close to the other gate post as possible, within two degrees is acceptable. The bottom of the template should be atleast 50mm from the ground. Trim down any protruding knots off the post so the template sits somewhat flat against the post with gaps no bigger than 15mm.



Using a 7.5mm drill bit, drill the 4 holes to a depth of approximately 80mm from the face of the template.



Remove the template

#### Step 9 – Fix to Post with Bottom Screw

With the help of a second person, lie the gate assembly on its side as pictured next to the gate so one of the bottom mounting holes on the gate mount lines up with the respective hole in the post.



Install one of the supplied coach bolts with washer about  $\frac{3}{4}$  of the way in but **DO NOT TIGHTEN!**



### Step 10 – Rotate the Whole Assembly into Place and Fix

Complete this step when there are only very light winds (less than 10km per hour).

With the help of a second person, rotate the whole assembly into the vertical position rotating on the bolt installed at step 9.



Install the last three coach bolts. You can make some fine adjustments with these bolts so the gate directly faces the other post providing you leave atleast 40mm of the coach bolt in the post. **IMPORTANT:** The coach bolts should be firm, but not so tight that it starts to bend the mounts or deform and twist the track which is easily done, so be careful.



### Step 11 – Install Solar Panel Bird Spikes

Depending on which angle you installed the solar panel, one end of the solar panel will be higher than the other. Install the supplied bird spikes onto the highest end of the solar panel using the supplied clear plastic clips.



## Step 12 – Install Earth Stake

Confirm there are no underground services in the vicinity of the gateway that the earth stake could possibly hit.

Install the supplied earth stake into the ground at the pictured position which allows the gate to rotate down without clashing with the stake. Leave about 200mm protruding out of the ground.



Connect the earth stake to the earth cable using the supplied earth clamp.



### Step 13 – Connect Battery and Power Up Circuit Board

Open the control panel door and connect the negative wire to the battery terminal.

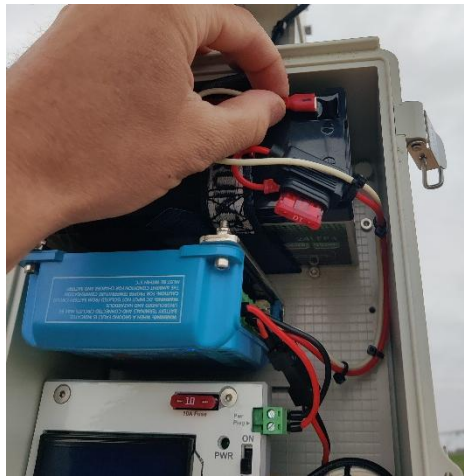

Turn ON the power switch located on the front of the control panel.

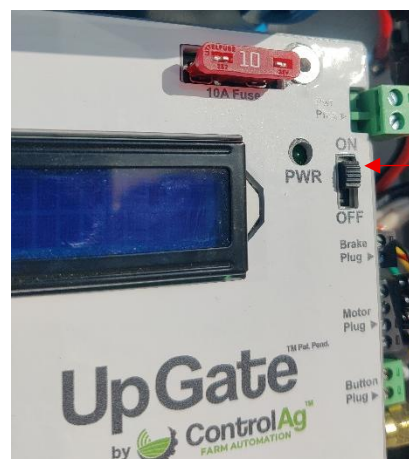

## Step 14 – Install Bungy Cords

Installing the bungy cord kit. You will have a blue handle on one end that electrically connects the bungy to the hook. Depending on if you are installing a two sided or one sided system, the other end will connect to another UpGate with a red insulated handle, or it will connect to a fence post using an insulator. **DO NOT OVERTIGHTEN the bungy cord** as this can cause excessive load on the motor and cause faults during opening. For every one metre width of gateway, there should be atleast 10mm of sag in the bungy cord. For example, a ten metre wide gateway should have atleast 100mm of sag.

Install the supplied yellow flag with a cable tie to the centre of the highest bungy cord for visibility purposes.



## Step 15 – Adjust Bungy Closed Heights

You may find that your bungy cord closed heights are already set in a pretty good position, if so skip to Step 17.

Press the release button and move the lowest shuttle by hand above the position you need it to stop. The release has a 1 minute timer, press again at any time if you run out of time.

Move the 40mm stopper pin bolt on the contact plate to the hole you need.

Press the release button again if it has timed out and move the shuttle down onto the stopper bolt.

Shuttles 2, 3 and 4 can be moved by hand without pressing the release button. Adjust the stopper bolt heights as necessary (corresponding bolt lengths detailed below). Leave the un-used stopper bolts stored in a spare hole on the contact plate.

Shuttle 2 (2<sup>nd</sup> lowest shuttle) will stop at the position you install the 17mm (entire length) shoulder bolt.

Shuttle 3 (3<sup>rd</sup> lowest shuttle) will stop at the position you install the 14mm (entire length) shoulder bolt.

Shuttle 4 (highest shuttle) will stop at the position you install the 13mm (entire length) cap head bolt.

## Step 16 – Adjust the Program Settings

**Number of bungy cords installed setting.** Navigate down to Settings → Strands → Set strands. Once set then press enter.

**Stop Position bolt setting.** Navigate down to Settings → Stop Position → Set Stop Position. Enter the Stop Position setting to correspond with the position of the stopper of the lowest bungy, then press enter. The stopper holes on the contact plate are numbered as below with 1 being the lowest and 7 being the highest.

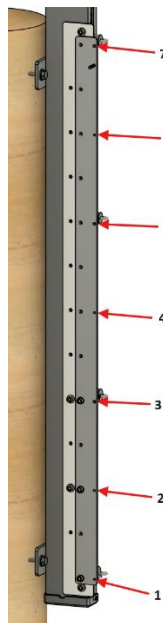

**Gate Width setting.** Navigate down to Settings → Gate Width → Set the Gate Width. This setting changes the speed of operation, the wider the gateway the faster the UpGate will operate.

**UpGate model setting.** Navigate down to Settings → Gate Type → Set the Gate Type. Large or Standard. Large UpGates have a top section 2350mm long, and the Standard 1730mm long.

After you have set these settings, wait for 5 seconds until the “Close gate with release button” message appears. Press the “Release” button which will allow you to move the lowest bungy manually by hand until it is pressing hard up against the Stop Position bolt. Pressing “Release” again will disable the function, or it will timeout after 1 minute.

### Step 17- Connect Up Electric Fence

Ensure there is an existing electric fence system isolator in good working order within 5 metres of the UpGate® for isolation of the UpGate® bungy cords in emergency situations.

Connect your existing electric fence system to the supplied stud on the contact plate but leave the electric fence system isolated for now. If this is a double sided UpGate system, **DO NOT CONNECT the side with the red insulated handle**, only one side is to be connected.



### Step 18 – Programming Remotes

If you ordered remotes in the same order as these UpGates, they will be already programmed and you can skip this step.

To program the remotes into the UpGate, navigate from Main Menu → Remotes → Add New Remote. Press the button number on your remote that corresponds to the number on the UpGate®. For example, if the UpGate® is labelled “1”, press button 1 on your remote. A message will display on the screen “Button added”.

Once completed, wait for 5 seconds to let it exit the menu.

If you make a mistake and you need to delete a remote refer to [3.5 Handheld remotes](#)

### Step 19 – Test

Run the UpGate® through 5 test operations.

If everything runs ok, turn on the electric fence system and ensure there are no obvious short circuits.

If you have any problems, refer to the troubleshooting guide in this manual.

## 4. Maintenance

### 5.1 Six Monthly Maintenance

**Step 1** - Leaving the gate installed, disconnect electric fence supply and clean with a brush and pump up spray bottle using fresh or soapy water every 6 months, or more regularly if problems occur with jamming or electric fence shorting.

**Step 2** - Inspect condition of post mounting system, no rust or corrosion. Also check the fence post is in good order.

**Step 3** - Clean the solar panel.

**Step 4** - Listen and look for signs of electric fence shorting. If problems are caused by shuttles or insulator refer to: [5.8 Replacing Insulator](#), [5.8 Replacing Shuttles](#)

**Step 5** - Check for any slack in the belt. If so tighten the belt by referring to: [5.6 Tightening a Loose Belt](#)

### 5.2 Two Yearly Maintenance

**Step 1** - Carry out [5.1 Six Monthly Maintenance](#)

**Step 2** - Visually check condition of battery (no bulges, corrosion). Replace if necessary.

**Step 3** - Visually check condition of insulator for signs of shorting (tracking lines, burn marks). Replace insulator if necessary.

**Step 4** - Refer to [5.11 Updating Firmware](#) to update the UpGate® control system to the latest firmware.

**Step 5** - Place the UpGate® into the [5.3 Maintenance Position](#) to complete the following maintenance checks.

**Step 6** - Check for signs of wear or damage on shuttles and belt. The belt should not have any cuts or missing pieces of rubber. The shuttles should not have any broken plastic, and the screws holding the wheels in place should not be rubbing on the aluminium track. Replace if necessary by referring to: [5.5 Replacing Belt](#), [5.7 Replacing Shuttles](#)

**Step 7** – Put back in service, refer to [5.4 Reinstate from Maintenance Position](#)

### 5.3 Placing into Maintenance Position

The following is instructions on how to place the UpGate® into the maintenance position for performing some of the maintenance tasks.

**Step 1** - Isolate the electric fence system and disconnect the UpGate® from the electric fence at the contact terminal bolt as shown below.



**Step 2** - Press the “Release” button and push all the shuttles up so the lowest shuttle ends up approximately 10mm (1cm) above the join in the tracks as shown below. Press the “Release” button again to turn off the release and hold them in place.



Step 3 - Turn the UpGate® power switch to OFF

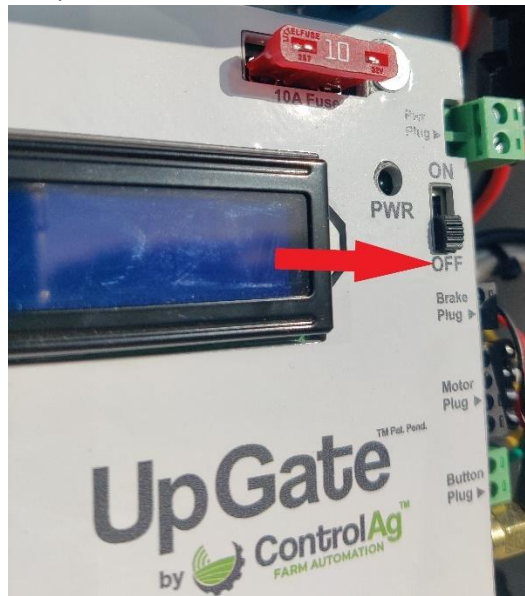

Step 4 - Disconnect the earth cable from the earth stake. Do not remove the earth stake.



**Step 5** - While one person holds the UpGate® upright, a second person removes both the upper mounting bolts and one of the lower mounting bolts. Slightly loosen the remaining lower mounting bolt only.



**Step 6** - Rotate the UpGate® down gently onto the ground



**Step 7** - Remove the bird spikes from the solar panel if they are on the outside edge of the solar panel so they are not going to get damaged at the next step.

**Step 8** - Completely remove the last mounting bolt and place the UpGate® so it is sitting as pictured using the solar panel as a stand.



**Step 9** - Remove the top cap

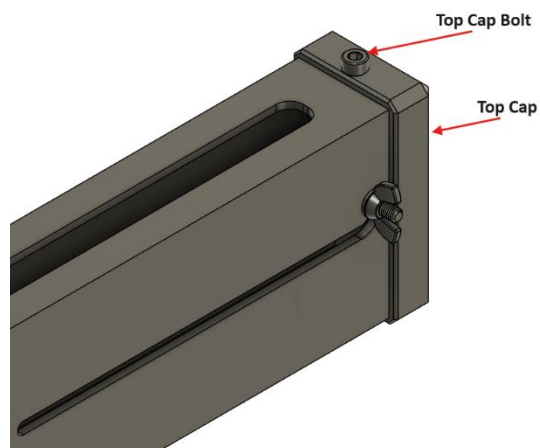

Step 10 - Loosen the wingnut and release the belt tensioner

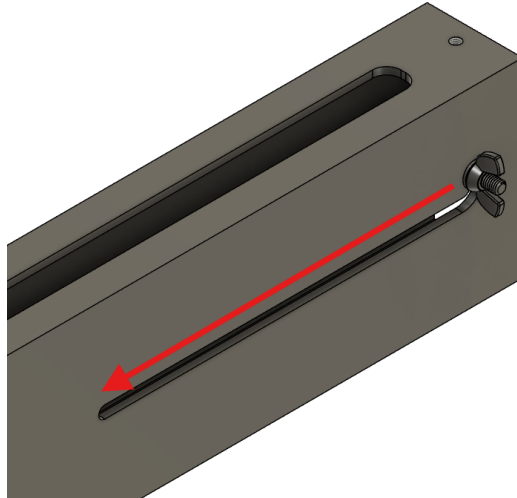

Step 11 - Refer to the below picture showing three bolts to remove and one bolt to loosen only!

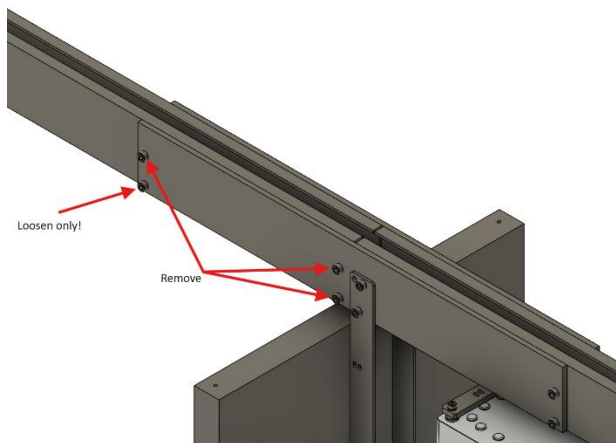

Step 12 - Rotate the top track down so the end of the track rests on the ground, being careful not to damage the belt at the join between the two tracks. This is now in the maintenance position.



## 5.4 Reinststate from Maintenance Position

The following are instructions on how to put the UpGate® back into service after it has been put into the maintenance position, and after you have completed maintenance/checks.

**Step 1** - Rotate the upper track into position being **careful not to jam the belt** in between the ends of the two tracks.

Place in the remaining joiner plate bolts as pictured below, taking care that the belts pass **ABOVE** the lower bolt.

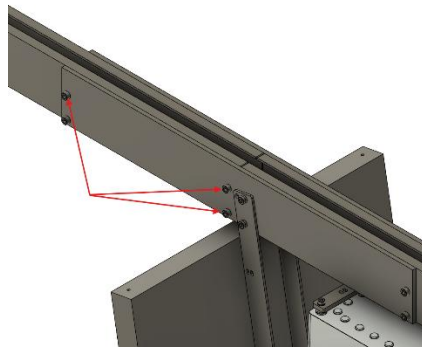

Image showing example of a belt passing ABOVE the lowest bolt.

**Step 2** - Tighten all eight join plate nuts only to the point the **washer stops feeling loose, DO NOT OVERTIGHTEN** the nuts. Any tighter than this and it will start to deform the track and can cause jamming of the shuttles during operation.

**Step 3** - Loosen the top tensioner pulley wing nut as pictured below just enough so it will slide in the slot. Locate the belt onto the pulley and pull the bolt so it locks into the highest point in the slot and tightens the belt. Tighten up the wing nut by hand.



**Step 4** - Looking down the centre of the tube you should not see any twists in the belt.

Step 5 - Install the top cap using the supplied bolt



Step 6 - With the help of a second person, lie the gate assembly on its side as pictured next to the gate so one of the bottom mounting holes on the gate mount lines up with the respective hole in the post.



Step 7 - Install one of the supplied coach bolts with washer about  $\frac{3}{4}$  of the way in, **DO NOT TIGHTEN!**



**Step 8** - Complete this step when there are only very light winds (less than 10km per hour). With the help of a second person, rotate the whole assembly into the vertical position rotating on the bolt installed in the previous step.



**Step 9** - Install the last three coach bolts. You can make some fine adjustments with these bolts so the gate directly faces the other post providing you leave at least 40mm of the coach bolt in the post. **IMPORTANT:** The coach bolts should be firm, but not so tight that it starts to bend the mounts or deform and twist the track which is easily done, so be careful.



**Step 10** - Connect the earth stake to the earth cable using the supplied earth clamp.



**Step 11** - Turn ON the power switch located on the front of the control panel.

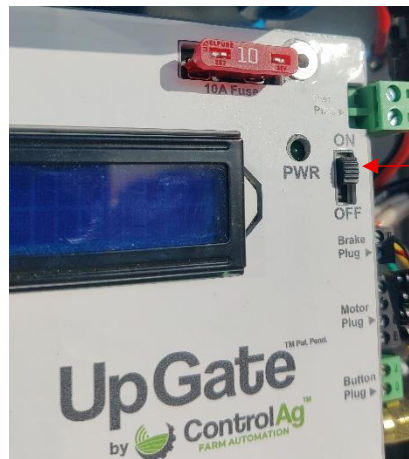

**Step 12** - Press the “Release” button and pull all the shuttles down to the closed position. Press the “Release” button again to turn off the release and hold them in place.

**Step 13** - Re-connect the electric fence to the contact plate bolt and re-energise your fencing system.



**Step 14** – De-isolate the electric fence system and test the gate through 3-4 operations to ensure smooth operation.

## 5.5 Replacing a Broken or Damaged Belt

**Step 1** - Place the UpGate® into the [5.3 Maintenance Position](#)

**Step 2** - Remove the pulley cover.

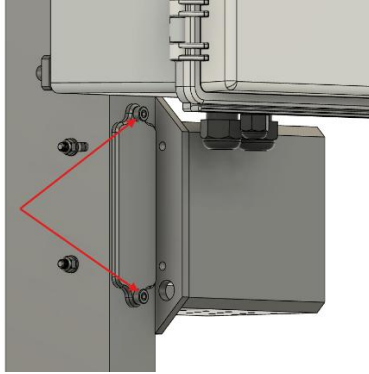

**Step 3** - Slide shuttle 1 out of the track and remove the 2 x belt locating screws on the rear of the shuttle.



**Step 4** - Remove the old belt completely from the UpGate®.

**Step 5** - Carefully study the diagram below showing the belt path and install the new belt with the teeth facing outwards and making sure that there are no twists in the belt.

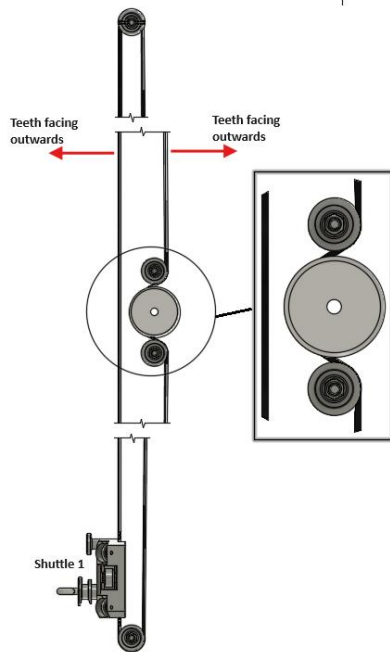

**Step 6** - Place the belt back into the shuttle 1 belt locating slots and reinstall the locating screws (**do not overtighten**, these do not need to be very tight) on the rear of the shuttle.

**Step 7** - Ensure the belt fine tensioner (pictured) is adjusted all the way to the front of the slot (away from the enclosure).

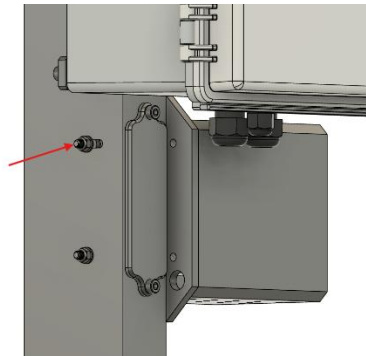

**Step 8** - Reinstall the pulley cover

**Step 9** - [5.4 Reinstate from Maintenance Position](#)

## 5.6 Tightening a Loose Belt

**Step 1** - Locate the belt fine tensioner on the side of the track. Slightly loosen the nut just enough so the bolt can slide within the slot.

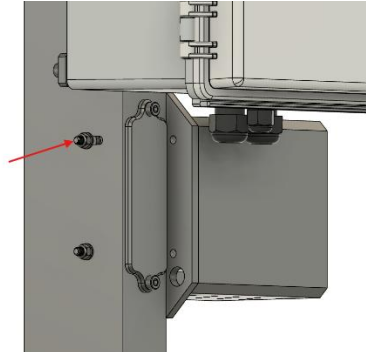

**Step 2** - Slide the bolt in the direction of the enclosure to tighten the belt. The belt tension does not need to be extremely tight, just enough to remove slack and a little bit more. A good way to test is by isolating the electric fence system and testing the movement in the lowest shuttle by hand to see if there is any slack.

**Step 3** - Re-tighten the nut to hold the tensioner in the new position.

## 5.7 Replacing Shuttles

**Step 1** - Place the gate into the [5.3 Maintenance Position](#).

**Step 2** - Replace any worn or damaged shuttles by sliding them into the top track. Take care to replace like for like, and keep them in order. The shuttles are labelled from 1 to 4 as pictured below, with the lowest shuttle being labelled number 1, and the highest labelled number 4. Replace a shuttle labelled 1, with a new shuttle labelled 1, and a shuttle 2 for a shuttle 2, and so on.

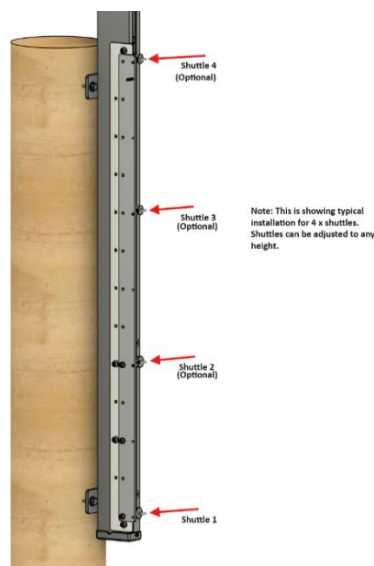

**Step 3** - Double check all the shuttles are in the correct order and are not upside down. The number label on the shuttle must be facing towards the top of the track.

**Step 4** - [5.4 Reinstate from Maintenance Position](#)

## 5.8 Replacing an Insulator

**Step 1** - Purchase a new insulator kit from us at ControlAg.

**Step 2** - Isolate the electric fence system

**Step 3** - Remove all the bolts holding the contact plate to the insulator and remove the contact plate.

**Step 4** - Remove all the bolts holding the insulator to the track and remove the insulator.

**Step 5** - Clean the area thoroughly before installing the new insulator and contact plate using the supplied new non-conductive bolts and washers, making sure to install the supplied shorter nylon bolt in the upper most position of the insulator to track hole.

**IMPORTANT:** Very gently tighten these bolts, they are plastic and are easily stripped! These bolts come with a special paste applied to help with insulation, please take care not to remove or contaminate it.

**Step 6** - De-isolate the electric fence system

## 5.9 Replacing Bungy Cords

**Step 1** - Purchase a bungy cord kit from ControlAg. You will have a blue handle on one end that electrically connects the bungy to the hook. Depending on if you are installing a two sided or one sided system, the other end will connect to another UpGate with a red insulated handle, or it will connect to a fence post using an insulator. **DO NOT OVERTIGHTEN the bungy cord** as this can cause excessive load on the motor and cause faults during opening. For every one metre width of gateway, there should be atleast 10mm of sag in the bungy cord. For example, a ten metre wide gateway should have atleast 100mm of sag.

**Step 2** - Install the supplied yellow flag to the centre of the highest bungy cord for visibility purposes.

**Step 3** – Test the operation of the UpGate with one side only which puts maximum tension on the bungy cords and motor. Loosen the belt if it fails to open.

## 5.10 Replacing Battery

**Step 1** – Purchase a new battery from us at ControlAg.

**Step 2** – Turn off electric fence system to reduce risk of electrical shock while performing maintenance

**Step 3** -Turn off the UpGate® by turning the power switch located next to the LCD screen to OFF.



**Step 4** – Carefully unplug the two wires from the battery

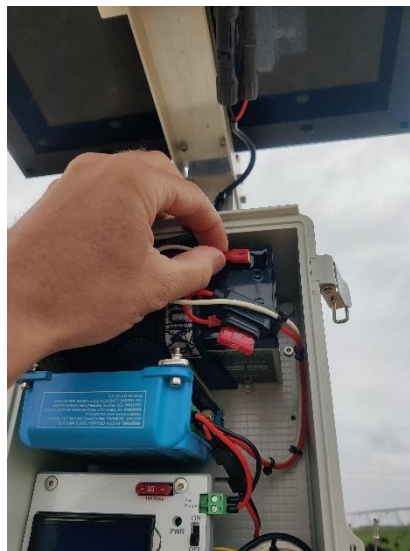

**Step 5** – With one hand holding the battery so it doesn't fall out, use your other hand to loosen the two straps allowing you to remove the old battery.

**Step 6** – Install the new battery with the terminals to the right hand side, ensuring that the battery is located above and beside the locator bolts and tighten the straps to secure the battery.

**Step 7** – Tuck the excess battery straps out of the way between the top of the battery and enclosure housing. This is important as otherwise it may get caught when closing the enclosure door and not allow a watertight seal.

**Step 8** – Re-connect the Positive + labelled wire to the Red terminal of the battery, and connect the Negative – labelled wire to the Black terminal of the battery.

**Step 9** – Turn on the UpGate® power switch

**Step 10** – Turn the electric fence system back on

## 5.11 Updating Firmware

**Step 1** - Download the latest firmware file from our website onto your smartphone.

**Step 2** - Turn the power switch on the UpGate to OFF for atleast five seconds, then power it back ON.

**Step 3** - Turn on WIFI on your phone and select the network with “UpGate” in its name. Password “12345678”. Your phone may detect that there is no internet connection via this network and ask you if you want to disconnect, do not disconnect.

**Step 4** - Open your internet browser (eg. Chrome, Safari).

**Step 5** - Type in and open the following website “192.168.4.1”. If it does not open, you may need to turn your sim card off in your phone settings so it forces your phone to use the WIFI connection to the UpGate.

**Step 6** - Select firmware check box.

**Step 7** - Select “choose file” and select the latest firmware file you downloaded at the first step.

**Step 8** - The file will upload and show a completed status. The UpGate controller will restart showing the firmware revision during startup which should match the firmware revision you downloaded. If you missed seeing the controller restart, just restart the controller again to see the version. If the version does not match the one you downloaded, please try again.

**Step 9** - Test the UpGate.

**Step 10** - Remember to turn your Sim card back on in your phone if you had to turn it off.

## 5 Troubleshooting

Please refer to the below table for troubleshooting the UpGate®. If none of the solutions rectify your problem, please do not hesitate to contact us for help.

Problem	Possible Causes	Solutions
No movement of the bungy cords but you can hear the motor operating.	Loose Belt	Refer to <a href="#">5.6 Tightening a Loose Belt</a>
	Broken belt	Refer to <a href="#">5.5 Replacing a Broken or Damaged Belt</a>
No response at all when operation commanded.	Fault condition in LCD	On the LCD display, scroll to "Faults" and press enter to see active fault readouts.
	Hand held remote control not programmed into UpGate® controller correctly	Refer to <a href="#">3.3 Handheld Remotes</a>
	Hand held remote faulty	Test the same button on another UpGate® to see if the problem is the hand held remote.
Operation fails during acceleration phase.	Number of bungy cords incorrectly set in settings.	Refer to settings instructions in <a href="#">3.8 Adding or Removing Bungy Cords</a>
	Obstruction/Debris in track.	Complete <a href="#">5.1 Six Monthly Maintenance</a>
	Worn or damaged shuttles.	Carry out the last two steps of <a href="#">5.2 Two Yearly Maintenance</a> to check the condition of the shuttles and replace if necessary.
Operation fails between acceleration and deceleration	Number of bungy cords incorrectly set in settings.	Refer to settings instructions in <a href="#">3.8 Adding or Removing Bungy Cords</a>
	Join plate bolts overtightened and jamming shuttles.	Loosen the join plate bolts. They should only be tightened to the point the washer stops feeling loose.
	Bungy cords adjusted too tight, or old bungy has lost its stretch causing motor overload.	Replace or loosen the bungy cord, for every one metre width of gateway, there should be atleast 10mm of sag in the bungy cord.
	Obstruction/Debris in track.	Complete <a href="#">5.1 Six Monthly Maintenance</a>
	Worn or damaged shuttles.	Carry out the last two steps of <a href="#">5.2 Two Yearly Maintenance</a> to check the condition of the shuttles and replace if necessary.

Operation fails during deceleration or stopping.	Number of bungy cords incorrectly set in settings.	Refer to settings instructions in <a href="#">3.8 Adding or Removing Bungy Cords</a>
	Incorrectly set Stop Position setting	Refer to settings instructions in <a href="#">3.2 Adjusting the Closed Height of the Bungy Cords</a>
	Incorrectly set Gate Width	Refer to <a href="#">Step 16 – Adjust the Program Settings</a>
	Incorrectly set Gate Type	Refer to <a href="#">Step 16 – Adjust the Program Settings</a>
	Bungy cords adjusted too tight, or old bungy has lost its stretch causing motor overload.	Replace or loosen the bungy cord, for every one metre width of gateway, there should be at least 10mm of sag in the bungy cord.
	Obstruction/Debris in track.	Complete <a href="#">5.1 Six Monthly Maintenance</a>
	Worn or damaged shuttles.	Carryout the last two steps of <a href="#">5.2 Two Yearly Maintenance</a> to check the condition of the shuttles and replace if necessary.
Driver Fault – Overcurrent, Overvoltage, Undervoltage	Obstruction/Debris in track.	Complete <a href="#">5.1 Six Monthly Maintenance</a>
	Worn shuttles or damaged shuttles.	Carry out the last two steps of <a href="#">5.2 Two Yearly Maintenance</a> to check the condition of the shuttles and replace if necessary.
	Faulty motor, motor brake or control board.	If you are experiencing re-occurring driver faults even after completing the previous steps, there could be a faulty motor or control board. Contact us for advice.
Low Battery warning – speed reduced. OR Very Low Battery warning – operations disabled	Dirty solar panel	Clean the solar panel
	Not enough sunlight	Confirm the correct adjustment of the solar panel at Chapter 4 <a href="#">Step 4 – Install Solar Panel Arm Assembly</a>
	Not enough sunlight	Clear any obstructions causing shade on the solar panel
	Too many operations	The amount of operations per day depends on how much the battery has been able to recharge from the solar system/sun. The alarm will clear automatically once it has recharged.
	Faulty Battery	<a href="#">5.9 Replacing Battery</a>

Electric fence system shorting	Dirty insulator and/or Shuttles	Complete <a href="#">5.1 Six Monthly Maintenance</a>
	Worn or damaged shuttles.	Carry out the last two steps of <a href="#">5.2 Two Yearly Maintenance</a> to check the condition of the shuttles and replace if necessary.
	Worn or Damaged Insulator	Complete <a href="#">5.8 Replacing Insulator</a>

## 6 Warranty

### **UpGate® Version 1 Parts-Only Warranty**

This Parts-Only Warranty is provided by ControlAg. Our contact details are provided in Section 5 below. This warranty applies to the UpGate® Version 1 Unit purchased in Australia and New Zealand and provides additional benefits to your consumer rights and remedies under the Australian Consumer Law and corresponding New Zealand consumer protection laws.

You can find more information about your consumer rights and guarantees provided by law in Australia at [www.accc.gov.au](http://www.accc.gov.au), and in New Zealand at [www.consumerprotection.govt.nz](http://www.consumerprotection.govt.nz).

We also provide this statement as required under the Australian Consumer Law:

Our goods come with guarantees that cannot be excluded under the Australian Consumer Law. You are entitled to a replacement or refund for a major failure and for compensation for any other reasonably foreseeable loss or damage. You are also entitled to have the goods repaired or replaced if the goods fail to be of acceptable quality and the failure does not amount to a major failure.

#### **1. What does our Parts-Only Warranty cover?**

ControlAg warrants that, when purchased new in Australia or New Zealand, all parts of the Unit are free from defects in materials and workmanship (Parts-Only Warranty) for the warranty period, subject to the terms and conditions outlined below.

The Parts-Only Warranty period is 24 months from the date of purchase of the Unit when installed in accordance with manufacturer specifications.

This warranty covers replacement of defective parts only and does not include labour, service, or associated costs related to removal, reinstallation, or troubleshooting of the Unit.

#### **2. Parts-Only Warranty Conditions**

The following terms and conditions apply to your Parts-Only Warranty:

- The warranty is effective from the date of purchase as indicated in Section 1 above.
- Proof of purchase of the Unit is required to make a warranty claim.
- The gate must be maintained and serviced according to the manufacturer's maintenance guidelines during the warranty period to ensure proper operation.

- Please refer to the User Manual for the UpGate® Version 1, available on our website or provided at the time of purchase, for additional information.

### **3. What is not covered?**

This Parts-Only Warranty does not cover:

- Labor or service costs for diagnosing, removing, or reinstalling parts.
- Batteries and other consumable components.
- Damage caused by improper installation, misuse, neglect, unauthorised modifications, external factors (e.g. lightning strikes, extreme weather conditions), or failure to maintain the Unit as per manufacturer guidelines.
- Any costs related to transportation, shipping, or handling, except as outlined in Section 4.

### **4. Where you need help with our product**

If you have a problem with the Unit or believe a part may be defective, please contact our Customer Service team below:

Phone: +61448850469

Address: 6 Richmond Court, Ocean Grove, Victoria, 3226

Email: [admin@controlag.com](mailto:admin@controlag.com)

Website: [www.controlag.com](http://www.controlag.com)

As a first step, our Customer Service team will provide product support assistance to help diagnose the issue. If further assistance is required, we may request that you return the defective part to us for inspection. Upon receiving the part, ControlAg will complete an assessment, and if we determine the part is eligible for warranty replacement, we will send a replacement part to you at no cost.

**Postage Reimbursement:** If the defective part is confirmed to be covered under this warranty, we will reimburse your postage costs up to a maximum of \$80. To claim this reimbursement, you must provide the postage receipt.

**Warranty Service Authorisation:** Prior authorisation from ControlAg is required for any warranty claims. Unauthorised returns may not be eligible for warranty service.

This Parts-Only Warranty applies only to the replacement of defective parts and does not cover labour or other associated costs. Your statutory rights under Australian and New Zealand consumer laws remain unaffected.

## 7 Technical Specifications

### Nominal Lifting Heights

All below calculations use a 150mm mounting height from the bottom of the UpGate® to ground level. The lifting heights below do not take into account sag in the bungy cord at the recommended minimum 10mm per one metre width of gateway, nor do they take into account unlevel ground. For example, if you have a gateway width of seven metres, you need to minus 70mm from the below table values, and add or subtract for unlevel ground.

#### UpGate® Standard

Bungy Cords	Lifting Height (mm)
1	4058
2	3993
3	3927
4	3859

#### UpGate® Large

Bungy Cords	Lifting Height (mm)
1	4678
2	4613
3	4547
4	4479

### Total Height

UpGate® Standard – 4088mm + mounting height from ground

UpGate® Large – 4708mm + mounting height from ground

**Minimum Post Size -** 150mm diameter (6 Inches)

### Nominal Operation Time

Operation time is the time to perform either an open, or a close.

For each differing amounts of bungy cords installed, the most likely Stop Position setting is given.

Bungy Cords	Stop Position setting	Operation Time in seconds
1	6	2.8
2	3	3
3	2	5
4	1	6

## 8 Spare Parts

For a comprehensive list of spare parts and accessories, please visit our website at [www.controlag.com](http://www.controlag.com). There, you will find detailed information and easy ordering options to ensure your equipment remains in top working condition

## 9 Intellectual Property

The UpGate® is protected by granted and pending patents in multiple countries. As the sole inventors and suppliers of the UpGate®, we hold exclusive rights to its technology. Our commitment to innovation is reflected in the extensive intellectual property protection we have secured to safeguard our technology.

The following Patent matters all have an earliest priority date of July 15, 2021 and claims priority to AU 2021902166 filed on July 15, 2021; PCT/AU2022/050640 filed on June 24, 2022.

### Granted Patents

- Country: **Australia**

- Patent Number: 2021902166

- Title: An Electric Strand Gate

- Filing Date: 15<sup>th</sup> July 2021

- Country: **United States**

- Application Number: 18/567,314

- Title: An Electric Strand Gate

- National Phase of: PCT/AU2022/050640

- National Filing Date: 5<sup>th</sup> December 2023

- Area: **Europe Unitary patent countries including United Kingdom**

- Countries covered – England, Scotland, Wales, Northern Ireland, Austria, Belgium, Bulgaria, Denmark, Estonia, Finland, France, Germany, Italy, Latvia, Lithuania, Luxembourg, Malta, The Netherlands, Portugal, Romania, Slovenia, Sweden.

- Application Number: 22840854.8

- Title: An Electric Strand Gate

- National Phase of: PCT/AU2022/050640

- National Filing Date: 5<sup>th</sup> December 2023

## Pending Patents

- Area: **United Kingdom**
- Application Number: 2318561.4
- Title: An Electric Strand Gate
- National Phase of: PCT/AU2022/050640
- National Filing Date: 5<sup>th</sup> December 2023
  
- Country: **New Zealand**
- Application Number: NZ 806172
- Title: An Electric Strand Gate
- National Phase of: PCT/AU2022/050640
- National Filing Date: 1<sup>st</sup> December 2023
  
- Country: **Canada**
- Application Number: 3221542
- Title: An Electric Strand Gate
- National Phase of: PCT/AU2022/050640
- National Filing Date: 24 June 2022